

Probe Selection Guide

Expand the Capabilities of any Hysitron System

The unique ability for Hysitron systems to offer interchangeable testing probes allows for users to select a probe that best fits the sample requirements.

Testing probes offered by Hysitron typically fit into one of the following three categories:

- Three-sided pyramidal probes
- Cono-spherical probes
- Specialty probes

Hysitron probes are constructed to exacting specifications to ensure a precise fit in any transducer.

Hysitron probes are built from an internally threaded synthetic tip holder. The machined tip, which is diamond unless otherwise specified, is installed into the square shaft as shown in figure 2.

All of the components used in the construction of the probes are carefully aligned along the vertical z-axis of the probe to ensure a standard machine compliance value over the probe life.

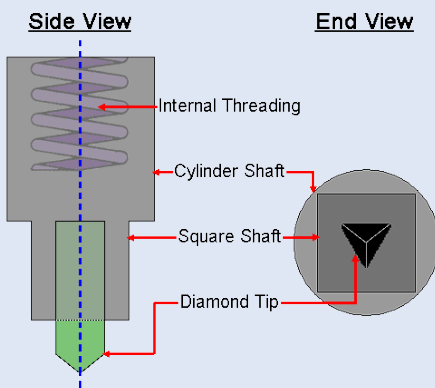

Figure 2. Composition of Hysitron probes.

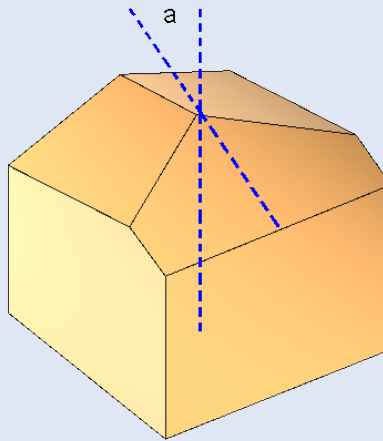

Figure 1. Schematic of three-sided pyramidal probe.

Three-Sided Pyramidal Probes

Three-sided pyramidal probes are the standard for nanoindentation. By machining three planes to a single point there will be a guaranteed single intersection location of the planes. This will result in the sharpest tip possible.

The standard three-sided pyramidal probe is the Berkovich probe. The Berkovich probe has a total included angle (plane to edge) of 142.3° and a half angle ($[a]$ in figure 1) of 65.35° . With an aspect ratio of 1:8, the Berkovich Probe was designed to have the same depth to area ratio as the Vickers probe (microindentation standard).

With an average radius of curvature of about 150 nm, the Berkovich probe is primarily used for bulk materials and thin films greater than 100 nm.

Another standard three-sided pyramidal probe is the Cube Corner tip. This tip has a total included angle of 90° and a half angle

of 35.26° . The Cube Corner probe also boasts an aspect ratio of 1:1 and an average radius of curvature ranging from 40 nm up to 100 nm.

Because of the smaller aspect ratio and sharper tip, the Cube Corner probe is typically used with samples where the plastic deformation must be confined to a much smaller volume such as ultra thin films or nanoparticles. Due to the sharp angle at the very end of this tip, the Cube Corner probe is also ideal when for high resolution in-situ imaging.

Cono-Spherical Probes

Cono-Spherical probes are conical shaped probes with a spherical end (figure 3). Due to the geometry of a Cono-Spherical probe, it is very difficult to attain the small radius of curvature that can be obtained with three-sided pyramidal probes. Cono-Spherical probes are typically divided into two groups: Imaging and Non-Imaging Cono-Spherical probes.

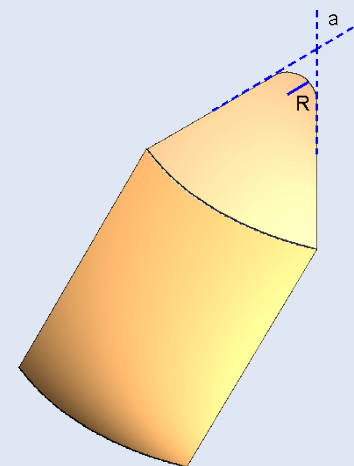
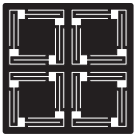

Figure 3. Schematic of a Cono-Spherical probe.



Imaging Cono-Spherical probes would be defined as having a radius $[R] \leq 10 \mu\text{m}$. Typically, imaging cono-spherical probes are used for nanoindentation on soft materials and nanoscratch testing. The radius of the Imaging Cono-Spherical probes are generally small enough to allow the user to perform in-situ imaging before or after locating the testing area.

Non-Imaging Cono-Spherical probes would be defined as having a radius $[R] > 10 \mu\text{m}$, and are primarily used for nanoindentation testing with very soft polymer or biological samples. The smaller stress concentration that is applied upon loading or when finding the sample surface will ensure that the tip does not go as deep into the sample with the set pre-load.

Both Imaging and Non-Imaging Cono-Spherical probes are available in an array of available cone angles $[a]$ with the standards being 60° , 90° and 120° . Because these tips are axisymmetric, Cono-Spherical probes are the preferred type of probe for most nanoscratch testing applications due to the uniform cross-section in any scratch direction.

Specialty Probes

Hysitron offers an array of specialty probes for custom applications. This includes simple geometries such as four-sided pyramidal Vickers or Knoop testing probes as well as slightly more specialized probes like a wedge or flat-ended tip. Hysitron also offers two additional probe assemblies that are used for specific testing regimes: Fluid Cell and Macor probes.

Fluid Cell probes (figure 4) are built specifically for use in testing samples that are submersed within a fluid. Available in any geometry, the fluid cell probe allows an additional 4 mm of clearance between the transducer and tip of the probe. This allows extra space for samples immersed in liquid. The shaft is more slender to reduce the meniscus forces at the tip/liquid interface.

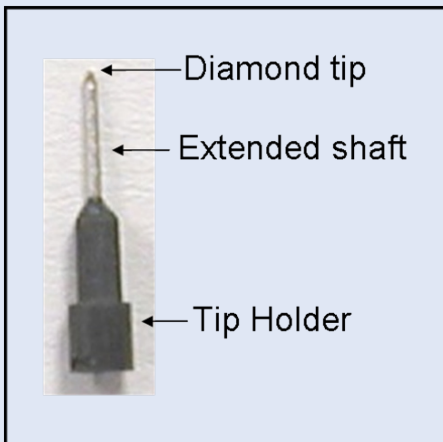

Figure 4. Photograph of fluid tip showing extended shaft for reduced meniscus force during testing.

Macor probes are built using a ceramic-based material in place of the standard probe holder. Macor probes are used for testing at high temperatures to reduce thermal conduction to the transducer and prevent the synthetic components of the standard probe holder from melting.

Hysitron also works directly with customers to develop new probe geometries and specialize existing probe geometries to better suit a defined testing requirement.

QUICK REFERENCE

Berkovich

Included angle: 142.3°
 Radius of curvature: $\sim 150 \text{ nm}$

Uses:

- Most bulk materials
- Thin films greater than 100 nm
- Hard polymers

Cube Corner

Included angle: 90°
 Radius of curvature: $\sim 40\text{--}100 \text{ nm}$

Uses:

- Ultra-thin films less than 100 nm
- Sample fracture/delamination
- Micro/nano structured materials

Cono-Spherical

Included angle: 60° , 90° or 120°
 Radius: $< 1 \mu\text{m} - 100 \mu\text{m}$

Uses:

- Polymers and biomaterials
- Nanoscratch/nanowear testing
- Structured samples (cantilevers, nano-springs, posts, etc...)
- MEMS/NEMS devices

Fluid Cell

Geometry: Any available

Uses:

- Samples submersed within a fluid
- Samples that require additional clearance to the transducer

Macor Assembly

Geometry: Any available

Uses:

- Extreme temperature testing for thermal isolation